

IMPORTANT SAFETY INSTRUCTIONS for indoor installation and portable use of units

WARNING When using electrical appliances, safety precautions to reduce the risk of fire, electric shock or injury to persons should be followed, including:

1. **READ ALL INSTRUCTIONS BEFORE USING THIS WATER HEATER.**
2. This water heater must be grounded. Connect only to properly grounded outlet. See” GROUNDING INSTRUCTIONS” found on “INSTALLATION INSTRUCTIONS”.
3. Install or locate this water heater only in accordance with the provided installation instructions.
4. Use this water heater only for its intended use as described in this manual.
5. Do not use an extension cord set with this water heater if you are mounting permanently in a building. If no outlet is available adjacent to the water heater, contact a qualified electrician to have one properly installed. Use an 12gaug extension cord if you are using the unit portably.
6. As with any appliance, close supervision is necessary when used by children.
7. Do not operate this water heater if it is not working properly or if it has been damaged or dropped.
8. This water heater should be serviced only by qualified service personnel. Contact a service person for examination, repair or adjustment.
9. Failure to service the anode rod at least once a year could cause the tank to fail and leak.
Any water heater should be installed in such a manner that if it should leak, the resulting flow of water will not cause damage to the area in which it is installed. National plumbing codes require a drain pan for any water heater installation. Failure to install one is the sole responsibility of owner and/or installer. Reference UPC 2000 (Uniform Plumbing Code) Section 510 – Protection from Damage or IPC 200 (International Plumbing Code) Section 504-Safety Devices.

KEEP THESE INSTRUCTIONS AT HAND-----SAVE THESE INSTRUCTIONS

TECHNICAL DATA

MODEL		GL 2.5 Ti	GL 4 Ti	GL 8 Ti
Capacity	gallons	2.75	3.85	8.0
Voltage	Vac	110/120 for each model		
Power at 120 Vac	Watts	1500	1500	1500
Maximum Water Pressure	psi	150	150	150
Weight	lbs	15.5	17.3	29.5
Amperage	Amps	12.5 amps for each model		
Phases		1	1	1

WARNING The installer should review the contents of this manual with the owner upon completion of installation, and the manual should be left with the owner and placed in a location close to the installation.

GENERAL REMARKS

CAUTION The manufacturer cannot be held responsible for the damages caused by improper installation or by the failure to follow instructions in this pamphlet. Comply with the installation instructions before completing electric connection.

CAUTION The thermostat has been pre-set at the factory at or below 51.7 °C (125°F).

CAUTION Hydrogen gas can be produced in a hot water system served by this heater that has not been used for a long period of time (generally 2 weeks or more). Hydrogen gas is extremely flammable. To reduce the risk of injury under these conditions it is recommended that the hot water faucet be opened for several minutes before using any electrical appliance connected to the hot water system. If hydrogen gas is present, there will probably be an unusual sound such as air escaping through the pipe as the water begins to flow. There should be no smoking or open flame near the faucet at this time.

CAUTION Any water heater should be installed in such a manner that if it should leak, the resulting flow of water will not cause damage to the area in which it is installed. National Plumbing Codes require a drain pan for any water heater installation. Failure to install one is the sole responsibility of owner and/or installer. Reference UPC 2000 (Uniform Plumbing Code) Section 504-Safety Devices.

HOTT WASH 2.5 - 4 - 8 GAL UNITS

FIG. 2/1

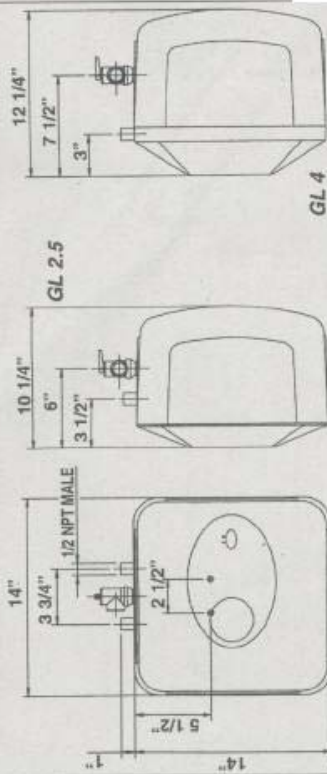

FIG. 2/2

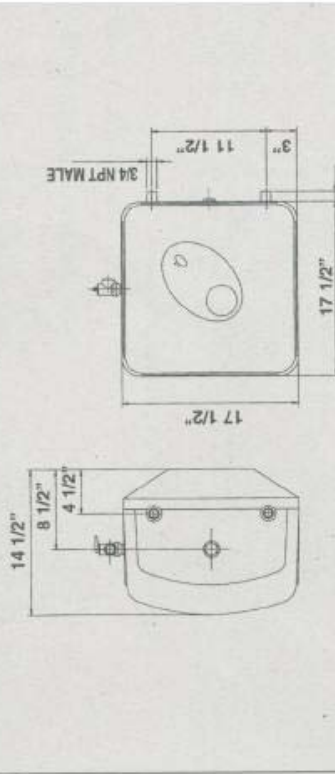

FIG. 2/3

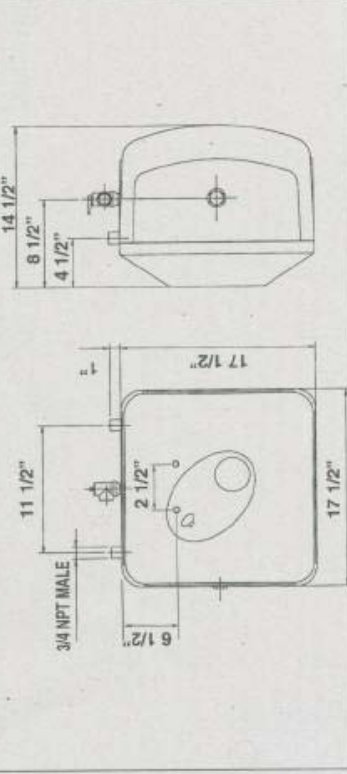
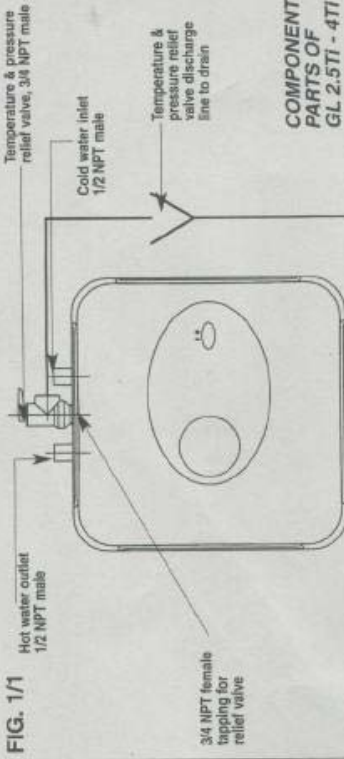
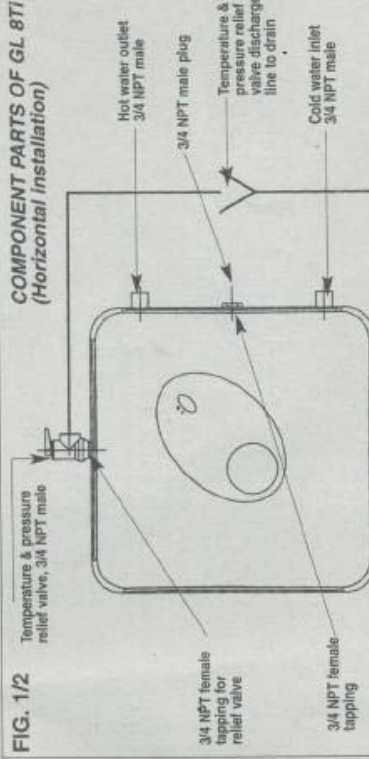

FIG. 1/1



COMPONENT PARTS OF GL 2.5Ti - 4Ti

FIG. 1/2



COMPONENT PARTS OF GL 8Ti (Horizontal Installation)

FIG. 1/3

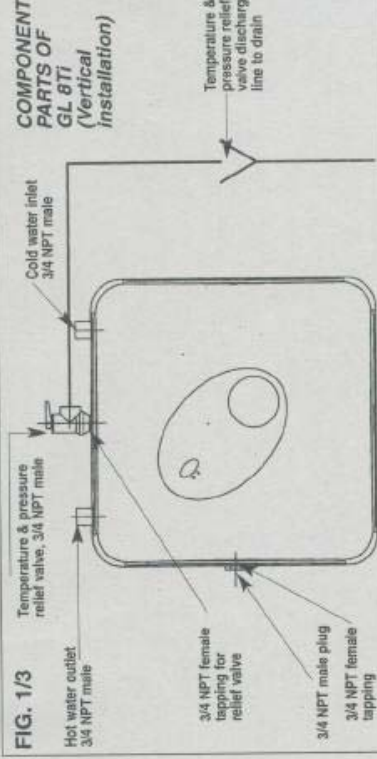

COMPONENT PARTS OF GL 8Ti (Vertical Installation)

INSTALLATION INSTRUCTIONS

Model GL 8 Ti

The GL 8Ti water heater can be installed under the sink.

Wall Mounting (only for vertical installation)

Fasten the supplied mounting bracket to the wall. Use screws that are suitable for the wall material and the weight of the heater. Hang the water heater on the bracket. Tug downwards on the heater to ensure that both “fingers” of the bracket are seated in the mounting slots. Confirm water piping orientation before wall mounting. Wall bracket will not support the GL8Ti when the plumbing connections are installed horizontally.

Floor Mounting

Heater can sit on floor. Confirm water piping orientation before using floor location.

Wiring and Grounding instructions

- As per the National Electric Code the GL8Ti needs to be wired with 12 GA. Wire to a minimum 20 amp/ maximum 20 amp branch circuit. To wire the GL8Ti model:
1. Pry off the round cover plate (**V Fig. 3/1**) from its right hand edge (**W Fig. 3/1**) with a small flat-head screwdriver.
 2. Remove the Phillips screw revealed beneath the round cover plate.
 3. The cover (**C Fig. 3/1**) can now be removed by pulling out its left-hand edge. When reassembling, work in the opposite way being careful to insert the tongue of the cover into the slot.
 4. Insert 12 AWG through conduit at rear of heater. Secure internal wire connector (**A Fig. 3/2**) and connect wiring to right side of thermostat control and ground. Positive (+) to lower terminal marked “L” (**E Fig. 3/2**) and Neutral to upper terminal marked “N” (**H Fig. 3/2**). Unit must be grounded at ground screw. (**T Fig. 3/2**) on element base.
 5. When the GL8Ti is not within sight of the electrical circuit breakers, a circuit breaker lockout or additional local means of disconnection for all non grounded conductors must be provided that is within sight of the appliance. [REF NEC 422.31]

Pipe connections

Connect the cold water inlet pipe to the inlet nipple (marked with a blue ring) and the hot water outlet pipe to the outlet nipple (marked with a red ring).

The model GL8Ti can be piped horizontally from the side or vertically from the top. If you wish to install the unit horizontally, with the piping connections on the right side, you will have to be certain the tap between the two water tapings is plugged, the supplied Temperature and Pressure Relief Valve will need to be installed on top. See location of T & P relief valve in Fig. 2/2.

If you wish to install the unit vertically, with the piping connections on top, you will have to be certain the tap on the side is plugged, the supplied Temperature and Pressure Relief Valve will need to be installed on top. See location of T & P relief valve in Fig. 2/3.

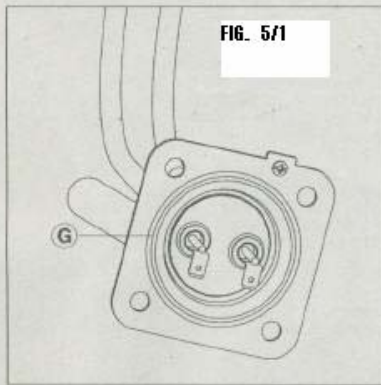

FIG. 5/1

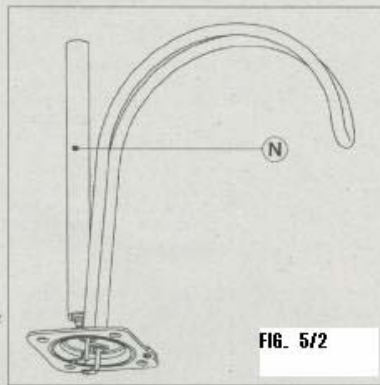

FIG. 5/2

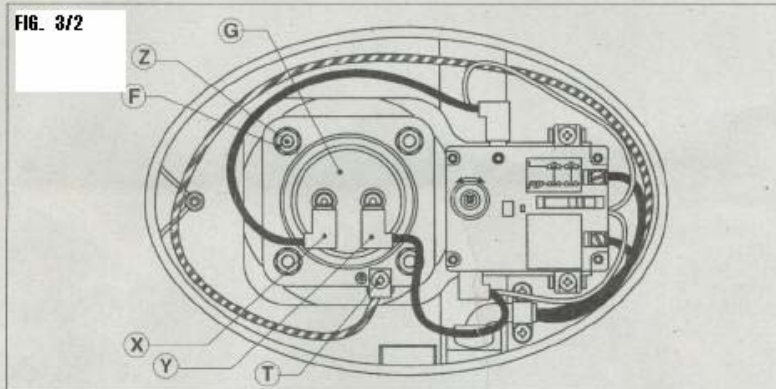

FIG. 3/2

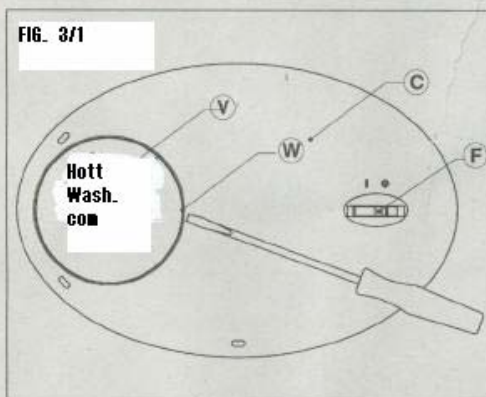

FIG. 3/1

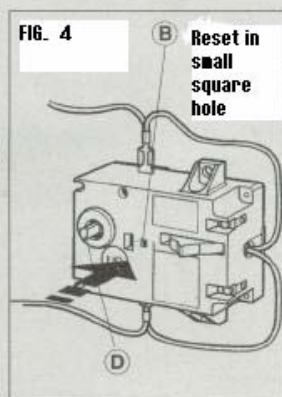

FIG. 4

Reset in
small
square
hole

The GL 2.5Ti and GL 4Ti water heaters can be installed under the sink.

Wall mounting	Fasten the supplied mounting bracket to the wall. Use screws that are suitable for the wall material and the weight of the heater. Hang the water heater on the bracket. Tug downwards on the heater to ensure that both “fingers” of the bracket are seated in the mounting slots.
Floor mounting	Heater can sit on the floor.
Pipe connections	Connect the cold water inlet pipe to the inlet nipple (marked with a blue ring) and the hot water outlet pipe to the outlet nipple (marked with a red ring).
CAUTION	<p>To reduce the risk of excessive pressures and temperatures in this water heater, install the supplied temperature and pressure protective equipment required by local codes but not less than a combination temperature and pressure relief valve certified by a nationally recognized testing laboratory that maintains periodic inspection of production of listed equipment or materials, as meeting the requirements for Relief Valves and Automatic Gas Shut-off Devices for Hot Water Supply Systems, ANSI Z21.22. The supplied temperature and pressure relief valve is marked with a maximum set pressure (150 psi) that does not exceed the marked maximum working pressure of the water heater. Install the valve in the opening provided and marked for this purpose in the water heater, and orient it or provide tubing so that any discharge from the valve will exit within 6 inches above, or at any distance below, the structural floor, and cannot contact any live electrical part. The discharge opening must not be blocked Or reduced in size under any circumstances.</p> <p>National Plumbing codes require a drain pan for any water heater installation. Failure to install one is the sole responsibility of owner and/or installer. Reference UPC 2000 (Uniform Plumbing Code) Section 510- Protection from Damage or IPC 2000 (International Plumbing Code) Section 504 – Safety Devices.</p>
Closed system thermal expansion (for all models)	<p>Periodic discharge of the temperature and pressure relief valve or failure of the element gasket may be due to thermal expansion in a closed water supply system. The water utility supply meter may contain a check valve, backflow preventer or water pressure reducing valve which will create a closed water system. During the heating cycle of the water heater, the water expands causing pressure inside the water heater to increase. The temperature and pressure relief valve may discharge hot water under these conditions which results in a loss of energy and a build-up of lime on the relief valve seat.</p> <p>To prevent this from happening, there are two recommendations:</p> <ol style="list-style-type: none"> 1. Install a diaphragm-type expansion tank that is suitable for potable water on the cold water supply line. The expansion tank must have a minimum capacity of 1.5 U.S. gallons for every 50 gallons of water stored. 2. Install a 125 PSI pressure relief valve in the cold water supply line. Make sure the discharge of this valve is directed to an open drain and protected from freezing. Contact the local water supplier or plumbing inspector for information on how to control this situation. Do not plug the temperature and pressure relief valve.
Instructions for use	
Starting and testing	<p>Before connecting the power, fill the tank and system with water and check for leaks. To be certain that all air is out of the water system, open the hot water faucets on your fixtures until constant water flows from them, otherwise damage to the element may occur.</p> <p>To start the heating cycle:</p> <ol style="list-style-type: none"> A) first make sure tank is full. Otherwise the heating element may be damaged. B) the red light will come on and remain on until that temperature has been reached, at which point the light will go off, but will automatically come back on when the water temperature drops below the setting chosen.
Temperature Setting	<p>After installation check the water temperature. If adjustment is necessary, remove front cover to adjust thermostat (D Fig. 4 – clockwise to increase the temperature and counter clockwise to decrease it).</p> <p>To reach the thermostat:</p> <ol style="list-style-type: none"> 1. Pry off the round cover plate (V Fig 3/1) from its right hand edge (W Fig 3/1) with a small flat-head screwdriver. 2. Remove the Phillips screw revealed beneath the round cover plate. 3. The cover (C Fig. 3/1) can now be removed by pulling out its left-hand edge. When reassembling, work in the opposite way being careful to insert the tongue of the cover into the slot.

Maintenance instructions

Note: Do not attempt to repair this water heater yourself. Call a service person for assistance. Always turn off the power supply to the heater prior to servicing or draining the heater.

Periodic maintenance

Note: For most of these operations, the water will have to be drained from the heater. for all of these operations the power supply needs to be shut off and the front cover removed.

1. Pry off the round cover plate (V Fig. 3/1) from its right hand edge (W Fig 3/1) with a small flat-head screwdriver.
2. Remove the Phillips screw revealed beneath the round cover plate.
3. The cover (C Fig. 3/1) can now be removed by pulling out its left-hand edge. When reassembling, work in the opposite way being careful to insert the tongue of the cover into the slot.

Draining the Heater

1. If the heater has been installed with flexible hoses, shut off the power supply and turn the heater upside down over a sink to drain the water out of it, OR
2. If the heater has been installed with rigid piping, siphon the water out through any (lower) service valve on the (inlet side). Keep a hot water faucet open while siphoning the water out, OR
3. If the heater has been installed with flexible hoses, it can also be emptied by siphoning through the inlet side hose. Keep a hot water faucet open while siphoning.

Note: opening the tab on top of the pressure relief valve: (lifting tab straight up will help the tank to drain faster)

Removing the heating element

1. Turn off power supply and drain the heater (see previous section).
2. Remove the front cover plate; disconnect terminals **X**, **Y** and **T** (fig. 3/2).
3. Unscrew the 4 heating element retaining nuts **F** (fig. 3/2).
4. Remove the element **G** (fig. 5/1).

Descaling the heating element

Scale deposits can affect the heating capability of the element. Heavy scale can even cause the element to burn out. The element can be descaled either chemically or manually.

- A. Soak the element in white vinegar or other descaling solution. Once descaled, rinse well with fresh water, to which you should add some baking soda, OR
- B. Once the element has dried up, use a soft brush (non metallic to prevent damaging the stainless steel sheath) on element. Brush the dried material off. Reinstall the element with gasket and make the wire connections.
- C. Replace anode rod (N Fig. 5/2) if it is noticeably deteriorated or considerably shorter than seen in figure 5/2.

WARNING: Make sure the tank has been refilled with water before restoring power.

Changing the anode Rod

The anode rod (**N Fig. 5/2**) helps protect the tank against corrosion. Depending on the water condition, the magnesium anode rod may need to be changed every year or so. Galvanic and electrolytic corrosion can destroy a tank if the anode rod is “spent”. Rusty water is usually an indication of a “spent” anode rod. If rusty water is present, examine anode rod immediately. Rapid degradation of the anode rod (less than 1 year) may indicate the presence of galvanic corrosion due to “stray” direct current. In this case, it may be necessary to add a “grounding strap” from the Ariston tank to the copper plumbing.

Changing the heating element

1. Turn off the power supply and drain the heater (see Draining the Heater)
2. Remove heating element (see previous section).
3. Remove and replace the anode rod **N Fig. 5/2**
4. **Refill tank with water before restoring power.**

Changing the thermostat

1. Turn off power supply.
2. Disconnect the 2 push/pull type wires on thermostat.
3. Loosen the two brass screws at right side of thermostat and pull wires out.
4. Unscrew and remove the two Phillips screws holding the thermostat down.
5. Install new thermostat and re-attach wiring and screws.

Resetting High Limit Switch

Occasionally, the high temperature limit shut off device may trigger and shut the system down. This occurs when water temperature exceeds 190° F and shuts off power to the heating element. The shut off device may also trigger from a power outage or electrical storm.

To reach the thermostat:

1. Pry off the round cover plate (**V Fig. 3/1**) from its right hand edge (**W Fig. 3/1**) with a small flat-head screwdriver.
2. Remove the Phillips screw revealed beneath the round cover plate.
3. The cover (**C Fig. 3/1**) can now be removed by pulling out its left-hand edge. When reassembling, work in the opposite way being careful to insert the tongue of the cover into the slot.
4. Firmly press reset button (**B Fig. 4**). Reconnect power.
5. **IMPORTANT:** Check the operation of the thermostat, turn temperature dial from high to low, if the red light does not go off on low setting, turn off power supply and call a service person to replace the thermostat.
6. If the system works, place dial setting to desired setting. Note: a lower setting is more economical and reduces the risk of scalding. Replace cover plate.

CAUTION: Call a technician if the high limit needs to be reset frequently.

Troubleshooting:**Water does not get hot**

1. Make sure the power supply is on and working.
2. If light does not come on, check that the reset button is pushed in; follow steps from previous section.
3. If the indicator light works properly but temperature does not get hot, a tap test for a plumbing crossover; shut off cold supply to heater and open hot water tap. There should be no water flowing. Any continued flow indicates a crossover which will effect the temperature and will need to be corrected.
4. Replace heating element (see previous section on changing the heating element).

Light not on

1. If the light does not come on, but water gets hot, check for faulty bulb.
2. Check reset button; follow steps from previous section.

Brown water

1. Brown or rusty water indicates a “spent” anode rod. Replace anode rod.

Odor in water

1. Smelly water could be due to an unusual reaction between local water and the Heater’s anode rod. Check anode rod (see section on changing the anode rod).

page 8

Water is too hot

1. Remove cover plate and turn the temperature selector dial (**D Fig. 4**) counter clockwise to lower temperature. If temperature never lowers then replace thermostat. (see section on changing the thermostat).

Water not hot enough
Leaking

1. Adjust the temperature selector dial (**D Fig. 4**) clockwise to increase temperature.
1. Check water fittings and T & P fitting on top of tank.
2. Remove front cover and inspect heating element gasket.

Hot Wash Portable & Hardwired Water Heaters

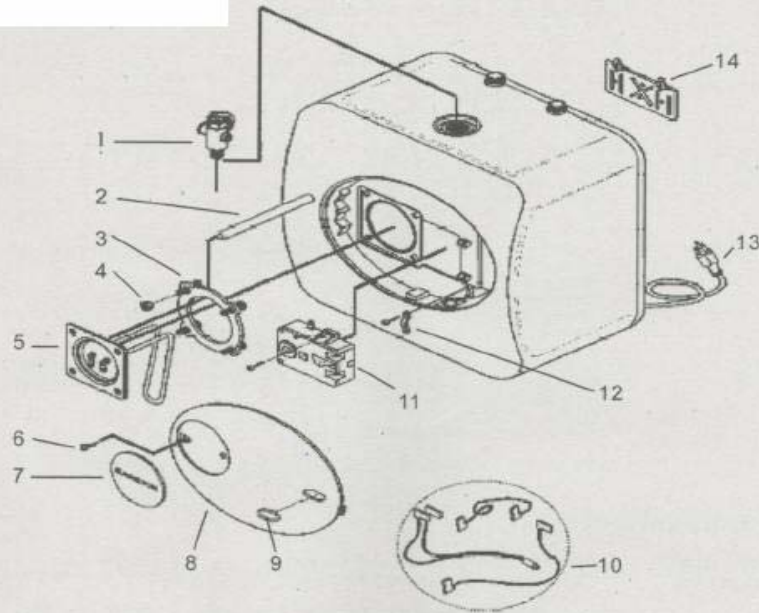

DESCRIPTION	REF.	PART CODE	DESCRIPTION	REF.
GL 2.5TI	A	1	100XL VALVE (TAP 3/4")	ABC
GL 4TI	B	2	570341 ANODE (MAGNESIUM)	C
GL 8TI	C	2	574305 ANODE (MAGNESIUM)	AB
		3	994147 GASKET WITH 4 BOLTS	ABC
		4	994148 LOCK NUT "M"	ABC
		5	994103 HEATING ELEMENT (1500/120)	AB
		5	994104 HEATING ELEMENT (1500/120)	C
		6	PLASTIC COVER RETAINING SCREW	
		7	NAME BADGE (PLASTIC)	
		8	COVER	
		9	SWITCH COVER	
		10	THERMOSTAT WIRING	
		11	994062 THERMOSTAT	AB
		11	994102 THERMOSTAT	C
		12	CABLE CLAMP	
		13	SUPPLY CABLE	AB
		14	570341 HEATER WALL HANGING BRACKET	ABC
		15	994103 3/4" BRASS PLUG (GL8 ONLY)	C

HOT WASH INTERIOR COMPONENTS DIAGRAM
GL 2.5, 4, 8

APPROVED : UL® CSA®
6K88 LISTED C US

AAI

PO Box 2153 New Preston, CT 06777 Tel: 860-868-1838

LIMITED 8 YEAR WARRANTY

Manufacturer guarantees this water heater to the owner (hereinafter "Owner") of the water heater at the original installation location against defects in material and workmanship for the periods specified below.

WARRANTY PERIOD

1. **The Inner Tank-** If the inner tank leaks within eight (8) years from the date of the original installation of the water heater, because of a defect in material or workmanship, Manufacturer will furnish to such Owner a new heater of the then prevailing comparable model.
2. **Any Component Part Other than The Original Inner Tank-** If any component part (other than the inner tank) proven to be defective in material or workmanship within one (1) year from the date of original installation of the water heater, manufacturer will furnish the Owner with a replacement of the defective part(s).
3. **Verification of Date of Original Installation-** When Owner cannot verify or document the original date of installation, the warranty period begins on the date of manufacture marked on the tag affixed to the water heater.

EXCLUSIONS

1. THIS LIMITED WARRANTY SHALL BE THE EXCLUSIVE WARRANTY MADE BY THE MANUFACTURER AND IS MADE IN LIEU OF ALL OTHER WARRANTIES, EXPRESSED OR IMPLIED (WHETHER WRITTEN OR ORAL), INCLUDING, BUT NOT LIMITED TO, WARRANTIES OF MERCHANTABILITY AND FITNESS, FOR A PARTICULAR PURPOSE.
2. The Manufacturer shall not be liable for any incidental, consequential, special or contingent damages or expenses arising, directly or indirectly, from any defect in the water heater or the use of the water heater.
3. The Manufacturer shall not be liable for any incidental, consequential, special or contingent damages or expenses arising, water damage arising, directly or indirectly, from any defect in the water heater component part(s) or from its use.
4. Manufacturer shall not be liable under this warranty if:
 - a) The water heater or any of its component parts has been subject to misuse, alteration, neglect or accident, or
 - b) The water heater has not been installed in accordance with the applicable local plumbing and/or building code(s) and/or regulation(s), or
 - c) The water heater has not been installed in accordance with the printed manufacturer's instructions, or
 - d) The water heater is not continuously supplied with portable water or is not filled with water completely before it is connected to a power source.
5. The Owner and not the Manufacturer or his representative shall be liable for and shall pay for all field charges for labor or other expenses incurred in the removal and/or repair of the product or any expense incurred by the owner in order to repair the product.

SOME STATES DO NOT ALLOW THE EXCLUSION OR LIMITATION OF INCIDENTAL OR CONSEQUENTIAL DAMAGES, SO THE ABOVE LIMITATION OR EXCLUSION MAY NOT APPLY TO YOU. THIS WARRANTY GIVES YOU SPECIFIC LEGAL RIGHTS AND YOU MAY ALSO HAVE OTHER RIGHTS WHICH MAY VARY FROM STATE TO STATE.

IMPORTANT: OWNER SHOULD REVIEW THIS SHEET BEFORE MAKING A CLAIM.

NOTE: A water heater should be installed in such a manner that if it should leak, the resulting flow of water will not cause damage to the area in which it is installed.

HOW THE OWNER CAN SECURE SERVICE OR MAKE A CLAIM

1. Owner should contact the dealer who sold the water heater covered by this warranty or
2. Owner should submit the warranty claim directly to manufacturer, and they will arrange for the handling of the claim.
3. Whenever any inquiry or service request is made, be sure to include the water heater model number, the date of manufacture, date of installation, Dealer's name and the watts and voltage.
4. When returning the water heater or component part(s), they must be individually tagged and identified with the Returned Goods Authorization # issued by manufacturer and shipped prepaid to manufacturer.